

PRODUCT SPECIFICATIONS

Zinc Chloride Dry Battery

R20P/SUM-1 D Size

(Mercury & Cadmium Free)

1. Scope

This specification is applicable to the cells supplied by Huarong Battery Co., Ltd.

2. Kind of products specified.

Manganese dioxide dry cell.

3. Type and characteristics.

- 3.1. Type (FR Designation): **13D R20P/SUM-1**
 (JIS Designation): **R20P SUM-1 (SP)**
 (IEC Designation): **R20P**

3.2. Nominal voltage : **1.5V**

3.3. Outside shape dimensions and terminals: In accordance to the appended drawing.

3.4. Appearance: Defects, such as flaws, dirty spots, deformation, discoloration, etc, with Damage commercial values shall not be present.

3.5. Characteristic

3.5.1. Design:

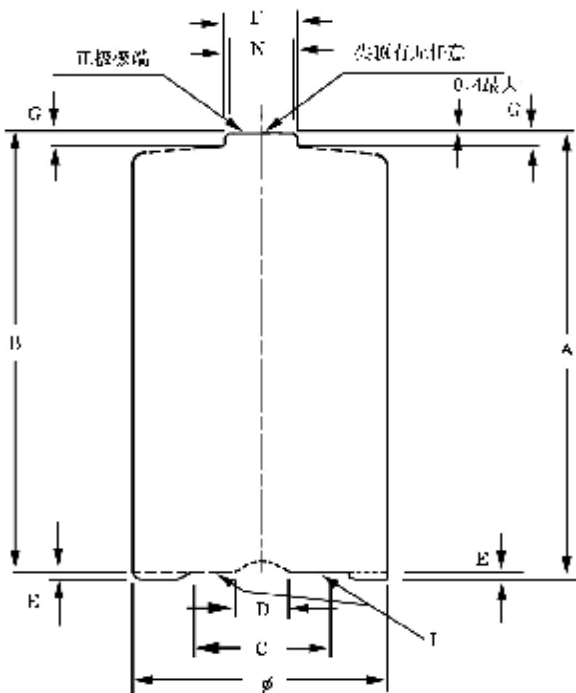
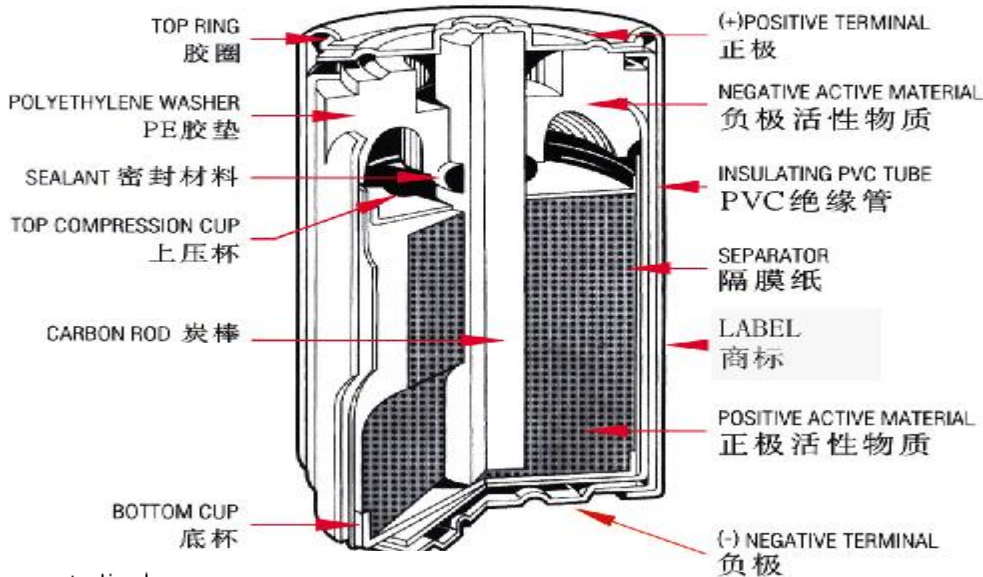

Unit : MM		
SIZE	R20P/SUM-1 D SIZE	
Measure No	Max	Min
A	61.5	
B		59.5
C		16.0
D	7.5	
E	1.4	
F	9.5	
G		1.5
N		7.8
Ø	34.2	32.2

DUREDAY BATTERY

- 3.5.2. Open-circuit voltage: Values shall be in agreement with that shown in Table 1.
 3.5.3. Service output: **ditto**
 3.5.4. Overdischarge electrolyte leakage resistance: **ditto**
 3.5.5. High temperature electrolyte leakage resistance: **ditto**

Table 1.

Open-Circuit Voltage:

Initial	1.520 to 1.720 V
After 12 months storage	1.500 to 1.720 V
Short Circuit Current (A)	7.0 A (at $20 \pm 2^\circ\text{C}$)

Service Output:

Load Resistance	2.2W	3.9W	2.2W	10W	3.9W	39 W
Discharge Method	4min/h 8h/d	1h/d	1h/d	4h/d	24 hrs/day	4 hrs/day
End-Point Voltage	0.9V	0.9V	0.8V	0.9V	0.9V	0.9V
Minimum Duration (Initial)	320min	13h	6h	35h	810 min	170 hrs
Minimum Duration (After 12 months storage)	256min	10h	4.8	30	760 min	30 min

Material Components

Average Weight: 102.0 g

<i>Material Components (Specific Chemical identity, Common Name(s))</i>	<i>AEGIH TLV</i>
1) <i>Manganese Dioxide</i>	30.0 %
2) <i>Graphite</i>	6.7%
3) <i>Zinc Metal</i>	25.9 %
4) <i>Carbon Black</i>	3.8 %
5) <i>Zinc Chloride</i>	4.7 %
6) <i>Ammonium Chloride</i>	0.3 %
7) <i>Lead</i>	0.0003 %
8) <i>Cadmium</i>	0.0010% (<10 PPM)
9) <i>Mercury</i>	0.0001% (<1PPM)

The word "initial" is applicable to the products elapsed one month or less after production, including those, to which tests have been started in less than three months after production.

4. Test

4.1. Storage and test conditions for sample cells

4.1.1. Storage conditions : Unless otherwise specified, the storage conditions for sample cells shall be, as a general rule. At the temperature of $25 \pm 2^\circ\text{C}$ and the humidity of $65 \pm 20\%$.

4.1.2. Test conditions : Unless otherwise specified, the test conditions for sample cells shall be kept at normal temperature ($20 \pm 15^\circ\text{C}$) and normal humidity ($65 \pm 20\%$).

4.2. Measuring instruments and devices

4.2.1. Voltmeter : The accuracy of the voltmeter shall be within 0.01V for each 1.5V.

The resistance of the measuring instrument shall be at least 10 times the discharge resistance but with a minimum of 500K ohms per volt of scale.

4.2.2. Load resistance: The load resistance shall include all of the external circuit, and its allowance shall be $\pm 0.5\%$.

4.2.3. Calipers : The calipers shall be the one having precision of 0.02 millimeters of Minimum scale, or the one having the same or super for precision to this.

4.3. Test method

4.3.1. Dimensions : Measurement shall be made by use of the calipers defined in 4.2.3.

4.3.2. Appearance : Examination shall be carried out by visual inspection.

4.3.3. Open-circuit voltage: Measurement shall be carried out before the start of discharge of the cell by use of the voltmeter defined in 4.2.1.

4.3.4. Service output

(1) **Discharge start time :** After leaving in an atmosphere at a temperature of $25 \pm 5^\circ\text{C}$ for at least 8 hours or more.

(2) **Discharge temperature and humidity:** $25 \pm 5^\circ\text{C}$, $65 \pm 20\%$.

(3) **Load resistance :** According to Table 1.

(4) **Discharge method:** In accordance to Table 1. However discharge shall be effected for more than 5 days during 7 days, and when discharge is made twice a day, an interval of 4 hours shall be elapsed between two discharges.

(5) **Discharge end-point:** The instant when the closed-circuit voltage has reached below the end-point voltage defined in Table 1.

4.3.5. Electrolyte leakage resistance

(1) **Overdischarge electrolyte leakage resistance**

The following conditions shall be adopted for the test.

(a) **Discharge start point :** After keeping at the temperature of $20 \pm 2^\circ\text{C}$ for at least 8 hours or more.

(b) **Test temperature and humidity:** $20 \pm 2^\circ\text{C}$, $65 \pm 20\%$.

(c) **Load resistance :** 20Ω

(d) **Test method :** Continuous discharge for 48 hours until 0.85V.

(2) **High temperature electrolyte leakage resistance**

The following conditions shall be adopted for the test.

(a) **Test temperature and humidity :** $45 \pm 2^\circ\text{C}$, below 70%.

(b) **Test period :** 30 days.

(c) **Test method :** Leave to stand still.

5. Guarantee

Guarantee period : *Within 24 months after shipped out.*

I teems to be noticed in handling.

Notices during use

- (i). To avoid such risks as leakage, heat evolution, explosion and human injury, following cares shall be taken.
 - a. Never let the cells be subjected to charging.
 - b. Put the cells in equipment by arranging their positive +and negative-terminals correctly as specified.
 - c. Never let the cells be short-circuited with a wire or a metal strip.
 - d. Never throw the cells into a bonfire.
 - e. Never heat the cells.
 - f. Never disassemble the cells.
 - g. Let the used cells be readily thrown away.
- (ii). As there is the fear of damaging equipment by the electrolyte leakage caused by excessive consumption, following notices are also required.
 - a. Never forget to turn the switch of equipment off.
 - b. When the equipment is left for a long time without being used, let the cells contained in the equipment is taken out of the equipment.
 - c. Take off the used and consumed cells immediately from the equipment.
 - d. Never make the mixed use of different kinds of cells such as manganese dry cells, alkaline cells and mercury cells.
 - e. Never make the mixed use of new cells with cells already subjected to use.

Notices during transportation and storage

As there is the fear of occurrence of such disadvantages as the promotion of characteristic deterioration, generation of stains and breakage, following notices are further required.

- a. Avoid such violent treatment as to throw the package of cells during transportation.
- b. Avoid the exposure to direct sunshine and the wetting by the rainy water and the like.
- c. Never expose cells to direct sunshine during storage, and never leave in a warehouse without draft, a covered wagon, etc.
- d. Never leave the cells in an atmosphere with the humidity of 80%or more for a long period during storage.

SPECIFICATION OF INSPECTION

We guarantee the quality of cells supplied from Huarong Battery Co., Ltd. satisfies the specification of the inspection. In case the cells are abnormal after shipment, the manufacturer shall examine the cause and if it is caused by manufacturing, we shall take measures immediately.

1. Quality standard : In accordance with the product specification.
2. Unit of inspection : One cell shall be one unit of inspection.
3. Definition of lot : A lot shall mean the cells manufactured by the same manufacturing system in principle and a group of products having the same manufacturing cord(month and year).
4. Test method : In accordance with the product specification.
5. Inspection plan and acceptability or iteria:

The inspection shall be carried out in accordance with the below table. But the inspection items shall be applied to only the initial inspection.

N o.	Inspection item	Inspection plan	Inspection level	Sampling plan	Acceptability criteria
1	Outside diameter	MIL-STD-105D	II	Single sampling	AQL: 1.0
2	Height dimension	MIL-STD-105D	II	Single sampling	AQL: 1.0
3	Appearance	MIL-STD-105D	II	Single sampling	AQL: 1.0
4	Open-circuit voltage	MIL-STD-105D	II	Single sampling	AQL: 1.0
5	Service output	JIS Z 9002	N=10	Single sampling	C=0
6	Over discharge electrolyte leakage resistance	JIS Z 9002	N=10	Single sampling	C=0
7	High temperature electrolyte Leakage resistance	JIS Z 9002	N=10	Single sampling	C=0